

VersaLSS-8™

The VersaLSS™ laser system is a fully integrated, plug and play, self-contained multiple wavelength output laser module. The individual lasers are based on the Stradus modules patented sealed optical cavity and the innovative electronics give the VersaLase unparalleled power stability, beam pointing stability, and low noise over time and temperature. Vortran's GUI software allow the user to control and monitor the system remotely via USB or RS-232.

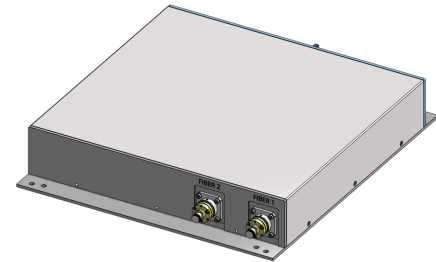

Specifications

Wavelengths (nm) Up to 8 Lines

375 ± 5, 395 ± 5, 405 ± 5, 420-425, 445 ± 5, 473 ± 5, 488 ± 5, 505 ± 2, 515 ± 5, 532 ± 1, 561 ± 1, 594 ± 1, 633 ± 3, 639 ± 5, 647 ± 5, 660 ± 10, 685 ± 10, 690 ± 10, 705 ± 10, 730 ± 10, 785 ± 10, 808nm ± 10

Power Output (mW, for each line at source)	Up to 300mW (-0%, +1-%)
Output (single or dual output options)	Free space, SM, PM and MM fiber options
Power Stability (over 24 hours)	<2%
Polarization Extinction Ratio	>100:1
RMS Noise (10 Hz to 10 MHz)	< 0.1 % < 0.15 % for 488 nm < 0.5 % for 532 nm < 0.25 % for 514 nm
Communication	USB-Micro B
Modulation Depth (for most wavelengths)	Infinite
Power Input	12V, 10A
CDRH Class (Dependent upon lasers selected)	Class 3b or Class 4
ESD Protection	Class 4
RoHS Compliance	EU and China
Dimensions (L x W x H)	16 x 14 x 3 in 403 x 362 x 70 mm

- Single Interface for Multiple-Wavelengths
- Free Space or Fiber Coupled
- USB Interface or RS-232
- Medical, Biomedical & Industrial
- Patented Sealed Optical Cavity
- Self-contained & Compact
- Unprecedented Lifetime Stability
- Excellent Beam Quality
- Low Noise

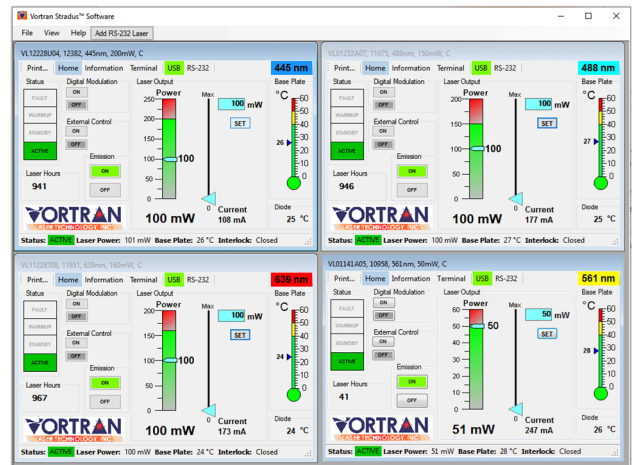

VersaLSS-8 Datasheet

Mechanical Drawing VersaLSS-8

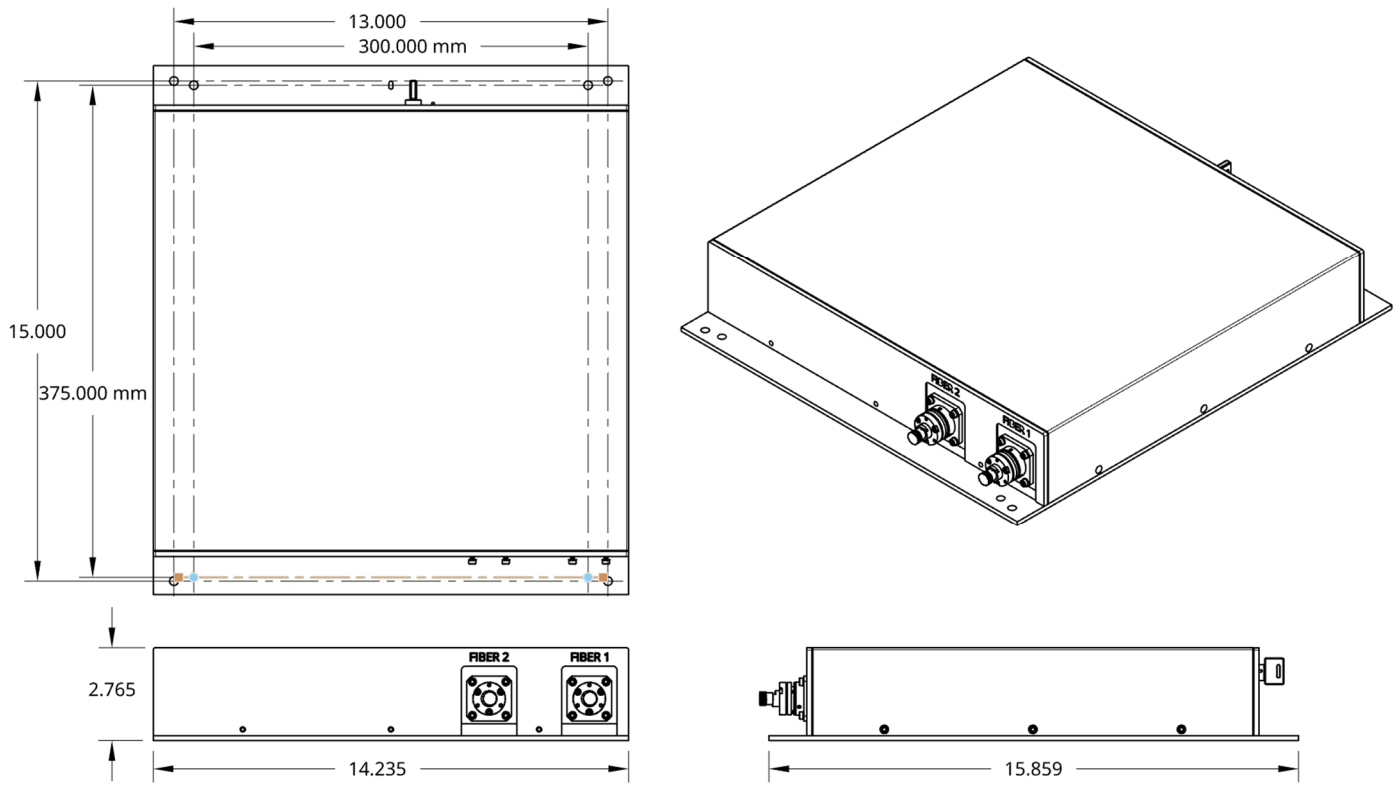

VersaLSS-8 Rear View

