

Kessil® PR300 USER MANUAL

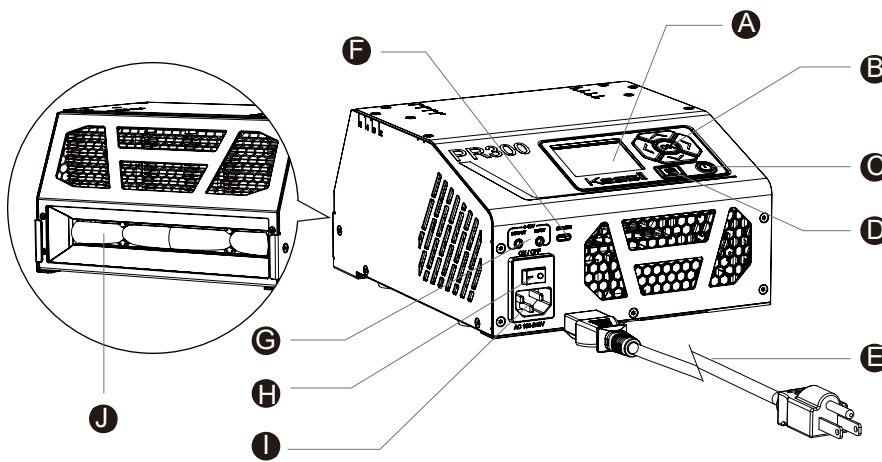

PARTS DIAGRAM



- A** LCD Screen
- B** Navigation Pad
- C** Pause Button
- D** Menu Button
- E** Power Cable
- F** USB Type-C Port
- G** Multi-Unit Link Port
- H** Main Power Switch
- I** AC Input Port
- J** Protective Glass

INSTALLATION GUIDE

1. Carefully take out the contents from the package.
2. Remove the adhesive film from the Protective Glass (J) before use. Clean periodically.
3. Connect the Power Cable (E) to the AC Input Port (I).
4. Plug the power supply into an outlet with the correct voltage specifications (see product specifications for more information).
5. Flip the Main Power Switch (H) to turn PR300 on and off, use the Navigation Pad (B) to change settings shown on the LCD Screen (A), and press the Menu Button (D) to return to Home Screen anytime without stopping the current step or program.
6. Press the Pause Button (C) to immediately pause and turn the light off anytime.
7. Plug the provided 3.5mm cables into the Multi-Unit Link Port (G) to sync multiple PR300 units.
8. Connect PR300 to a computer through the USB Type-C Port (F). Does not need to be connected to a computer to run.

PRODUCT SPECIFICATIONS

Power Consumption	MAX 340W
Input Voltage	100 - 240 VAC
Irradiation Distance*	20mm - 50mm
Wavelength Options	427nm, 440nm, 456nm, 467nm, 525nm
Average Intensity of PR300 series (Protective Glass as starting point)	442 mW/cm ² measured at 20mm
Dimensions (W x L x H)	7.9" x 9.3" x 4.5" / 20.0cm x 23.6cm x 11.5cm

* From Protective Glass to vials placed in the Tank

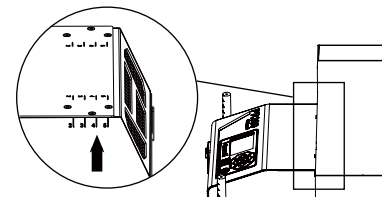

WARNING & SAFETY INSTRUCTIONS

1. CONTAINS HIGH INTENSITY LIGHT
2. SOME MODELS HAVE ULTRAVIOLET (UV) LIGHT
3. DO NOT LOOK DIRECTLY AT LIGHT
4. AVOID EYE & SKIN EXPOSURE. WEAR PROPER EYE & SKIN PROTECTION
5. DO NOT OPERATE IN WET OR HUMID ENVIRONMENT
6. DO NOT BLOCK AIR VENTS. ALLOW FOR COOLING
7. DO NOT MODIFY FIXTURE OR PARTS IN ANY WAY
8. OPERATING TEMPERATURE 0 - 40°C (32 - 104°F)
9. ONLY USE SUPPLIED POWER SUPPLY AND WITHIN RATINGS
10. INSTALL PROTECTIVE GLASS BEFORE USE AND KEEP SURFACE CLEAN. REMOVE AND PUT BACK INTO PACKAGE BEFORE SHIPPING
11. ALWAYS KEEP PR300 UPRIGHT TO PREVENT PROTECTIVE GLASS FROM SLIDING

AVERTISSEMENTS ET CONSIGNES DE SÉCURITÉ

1. CONTIENT UNE LUMIÈRE DE HAUTE INTENSITÉ
2. CERTAINS MODÈLES SONT DOTÉS D'UNE LUMIÈRE ULTRAVIOLETTE (UV)
3. NE REGARDEZ PAS DIRECTEMENT LA LUMIÈRE
4. ÉVITEZ L'EXPOSITION DES YEUX ET DE LA PEAU. PORTEZ UNE PROTECTION APPROPRIÉE DES YEUX ET DE LA PEAU
5. NE PAS UTILISER DANS UN ENVIRONNEMENT HUMIDE OU HUMIDE
6. NE BLOQUEZ PAS LES OUVERTURES D'AÉRATION. PERMETTRE LE REFROIDISSEMENT
7. NE MODIFIEZ PAS LE LUMINAIRE OU LES PIÈCES DE QUELQUE MANIÈRE QUE CE SOIT
8. TEMPÉRATURE DE FONCTIONNEMENT 0 - 40°C (32 - 104°F)
9. UTILISEZ UNIQUEMENT L'ALIMENTATION ÉLECTRIQUE FOURNIE ET DANS LES LIMITES DES VALEURS NOMINALES
10. INSTALLER LE VERRE DE PROTECTION AVANT UTILISATION ET GARDER LA SURFACE PROPRE. RETIRER ET REMETTRE DANS L'EMBALLAGE AVANT L'EXPÉDITION
11. TOUJOURS GARDEZ LE PR300 EN POSITION VERTICALE POUR ÉVITER QUE LE VERRE DE PROTECTION NE GLISSE

OPTIONAL ACCESSORIES

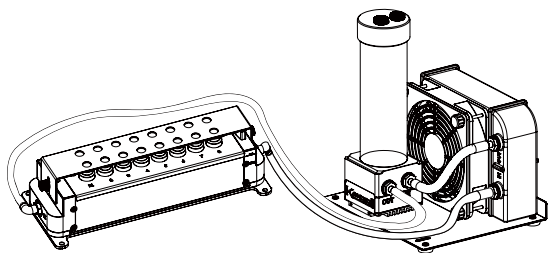

PR300 Water Cooling System

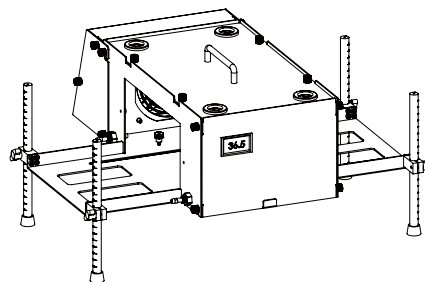

PR300 Shielding Box

MAINTENANCE

1. Keep the venting holes and fan free of dust. To clean, unplug the unit and use a CO2 dust blower (or similar tool) to gently clean through the venting holes. Alternatively, you can use a vacuum to remove dust.
2. Keep the Protective Glass (J) clean. If it becomes contaminated with water, dust, or other particles, unplug the unit and gently wipe the glass cover with a cotton swab or cloth dampened with isopropyl alcohol. Allow to dry completely before using the unit again.

TROUBLESHOOTING GUIDE

Problem	Solution
Light doesn't turn ON	Make sure the unit is connected to the power supply and the power supply is plugged into an outlet with the correct specifications.
	Confirm that the AC outlet being used provides electrical power.
	Verify that the power supply meets the required specifications.
Unit is flickering	Make sure the device is operating within the specified temperature range 0 - 40°C (32 - 104°F). If the unit overheats, it will shut down automatically.
	Verify that the power supply meets the required specifications.
	Make sure the unit has not overheated by operating and that the operating temperature does not exceed 40°C (104°F).
	Confirm that the fan is operating properly.

INSTRUCTIONS

Button Function



Press
Up/Down Move



Press
Left/Right Move



Press
Confirm

Manual

1. Navigate to set the Intensity. Press OK to confirm.
2. Move down to "Start" and press OK to start the timer and turn on the light at the chosen intensity level.
3. Press OK on "Pause" to pause the timer and turn off the light anytime. Select "Resume" to turn the timer and light back on.

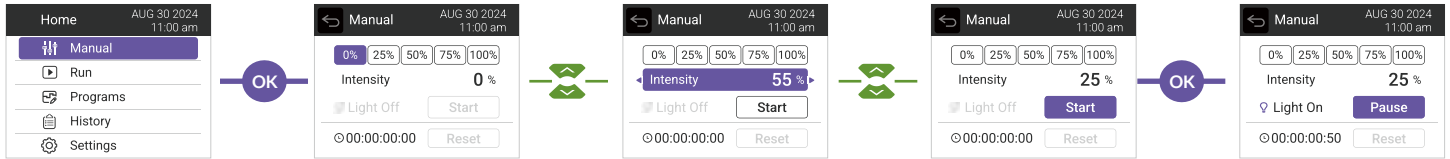

Run

1. Press OK to select the desired program name.
2. Navigate to view the program details and move left/right to go to the next/previous page.
3. Move down to adjust the "Start Time", then press OK on "Run" to start the program.
4. Press "Hold" to hold this step and keep light on (timer continues); press "Pause" to hold this step and keep light on (timer pauses); press "Abort" to end the program.

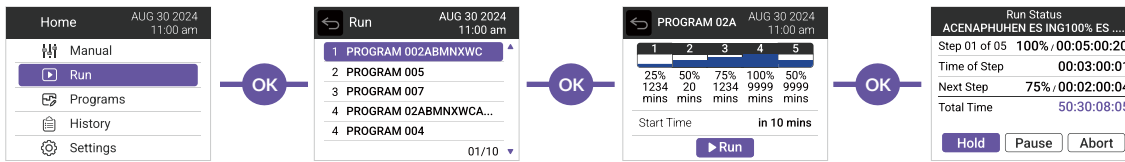

Programs

1. Press OK on "Add Program" to add a new program.
2. Adjust Intensity and Duration using the navigation pad.
3. Add a new step by clicking "+" icon.
4. Use "Go to Step" to repeat specific steps in sequence for a specified number of cycles.
5. Select "Step" to delete the current step.

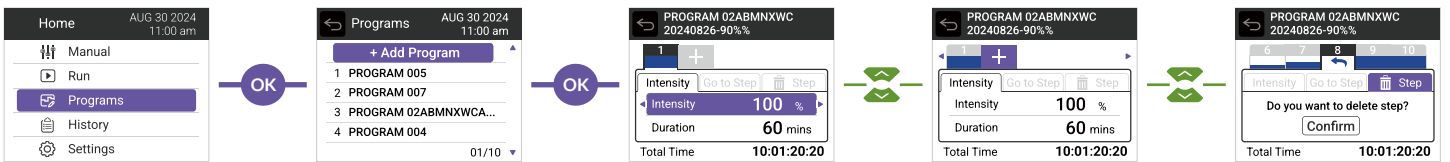

History

1. Move up/down the list of program names with the last run date.
2. Press OK to view the last run details.

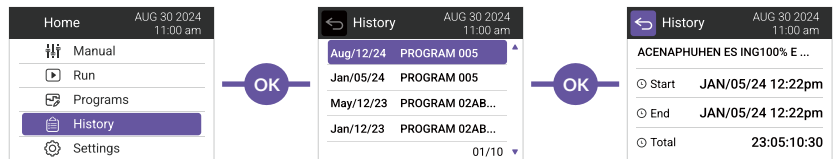

Settings

1. Move up/down to select the menu.
2. Press OK to enter a setting and move left/right to adjust the values.

