

# Picosecond Delayer OEM

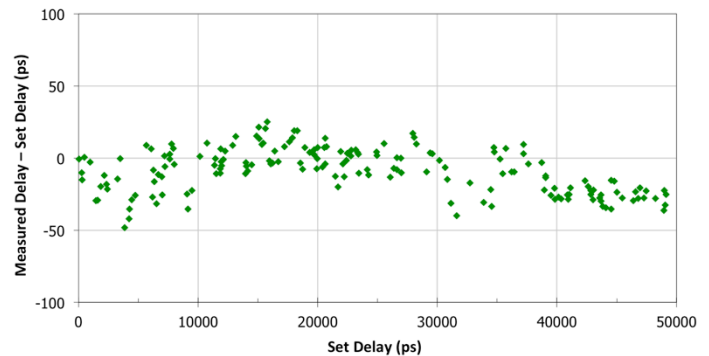
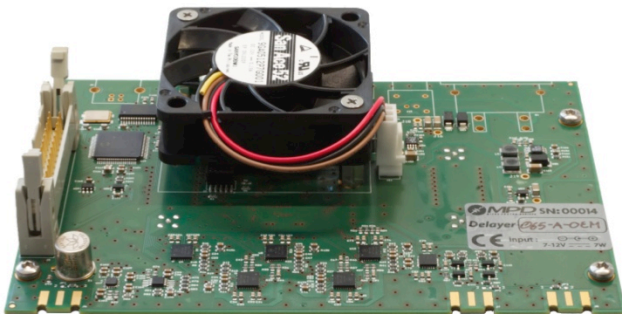

MPD Picosecond Delayer is a module capable to generate output pulses with user-selectable delay and output pulse duration, in respect to the rising or falling edge of the input signal. This new instrumentation, completely based on solid-state components, sets a new milestone with best in class precision, time-jitter and stability over a wide range of temperatures, not even matched by standard coaxial cables.

- ▶ **Fine adjustable picosecond delayer**  
10ps resolution and programmable output width
- ▶ **Very high bandwidth and low jitter**  
Up to 380 MHz with random jitter of 5ps RMS
- ▶ **Dual output**  
TTL and NIM
- ▶ **High performance uniformity**  
INL between +50ps & -100ps
- ▶ **Frequency divider**  
Input frequency can be divided by a factor up to 999

## MODULE FEATURES

- 50 ns maximum delay range
- 10 ps step
- TTL and NIM output pulses
- up to 380 MHz bandwidth (NIM output)
- programmable output width from 1 ns to 250 ns
- INL between +50 ps and -100 ps over full-scale range and for all temperatures
- random jitter typ. 5 ps RMS
- < 1 ms programming time
- USB interface
- All solid state, no coax cables

## BIOMEDICAL APPLICATION

- Correlation Measurements
- Spectroscopy
- Time-correlated single photon counting
- Optical Tomography

## INDUSTRIAL APPLICATION

- Streak camera synchronization
- Short gate acquisition experiments

## QUANTUM APPLICATION

- Quantum Cryptography
- Single-photon source characterisation

## ASTRONOMY APPLICATION

- Optical Range Finding, LIDAR & LADAR

## Overview

The MPD Picosecond Delayer is a module capable to generate output pulses (both NIM and TTL) with user-selectable delay and output pulse duration, in respect to the rising or falling edge of an input signal. It can act also as a frequency divider by a user selectable positive integer ranging from 1 to 999. This new instrumentation, completely based on solid-state components, sets a new milestone with best in class precision, time-jitter and stability over a wide range of temperatures, not even matched by normal coaxial cables.

The delayer features a 50 ns nominal full scale range with a 10 ps step delay resolution, whilst the output pulse duration is also user controllable from 1 ns to 250 ns with a nominal step of 3.3 ns.

The excellent integral non linearity error is comprised between +50 ps and -100 ps over the full scale range and for all operating temperatures. This exceptional performance makes the picosecond delayer the perfect choice for any experimental set-up where signals must be delayed with high accuracy and stability of characteristics over a broad range of delays and temperatures.

The low random jitter makes it also successfully suitable in any Time Correlated Single Photon Counting application.

The MPD Picosecond Delayer -OEM version- allows the exploitation of such characteristics, inside custom build instruments, through the use of a compact daughter board.

## Board integration

All the signals and power lines are routed and/or fed through two special connectors (J5 and J20), mounted at the bottom of the daughter board and shown here below. Thanks to this connectors it is possible not only to access to the delayer's input and outputs but also to talk directly to the internal microcontroller both via a USB bus (the provided USB driver will create a Serial "Virtual COM" on the host PC, exactly as the one employed in the \$PSD-065-A-MOD) and via an additional UART interface. The communication with the board is obtained by sending ASCII strings over the virtual COM or directly to the Picosecond Delayer microcontroller through the UART interface (pins TX1 and RX1). Other useful signals or still unused lines for future development are also already routed to the special connectors.

The MPD Picosecond Delayer can be operated, for diagnostic purposes, through a PC interface that exploits the USB Virtual Serial COM. Finally, in order to introduce new features or correct found bugs it is possible to update the Picosecond Delayer microcontroller's firmware and the CPLD firmware. This can be achieved through the use of the USB Virtual COM port and a PC with Microsoft Windows® installed. For these reasons, the recommended way of controlling the board is by direct communication through the UART interface, while leaving the USB one only for diagnostic and firmware updates.

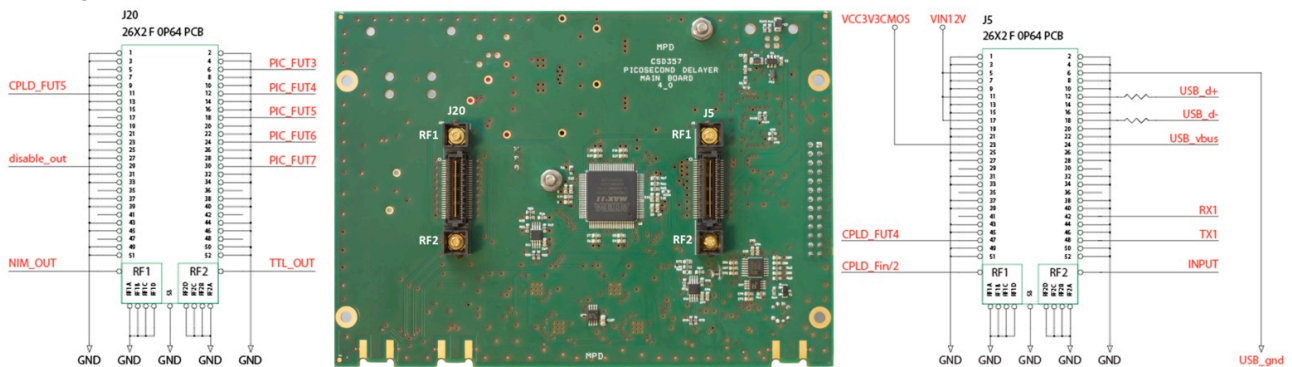

## Specifications

Parameter	Symbol	Description	Min.	Typ.	Max.	Unit
Input high voltage	$V_{IN\_High}$				3	V
Input low voltage	$V_{IN\_Low}$		-2			V
Input differential range	$V_{D\_MAX}$		-2		2	V
Input termination	$R_{IN}$			50		$\Omega$
Input voltage overdrive	$V_{OV}$		100			mV
Input pulse width	$t_{IN}$		100			ps
Input Slew Rate	SR		100			V/ $\mu$ s
Input overdrive dispersion		100 mV < $V_{OV}$ < 1 V		10		ps
Input slew rate dispersion		2 V/ns < SR < 10 V/ns		15		ps
Input Edge			Neg/pos			
Input Threshold	$V_{TH}$		-2		2	V
Input threshold resolution	$\Delta V_{TH}$		10	18	30	mV
NIM Output low logic level	$V_{NIM\_High}$	50 $\Omega$ termination required		0		V
NIM Output high logic level	$V_{NIM\_Low}$	50 $\Omega$ termination required		-800		mV
NIM Output Bandwidth	$BW_{NIM}$		300	380		MHz
TTL Output Bandwidth	$BW_{TTL}$		100	120		MHz
TTL Output low logic level	$V_{TTL\_Low}$	50 $\Omega$ termination required		0		V
TTL Output high logic level	$V_{TTL\_High}$	50 $\Omega$ termination required	2.4			V
Propagation delay INPUT - NIM OUT	$t_{PD\_NIM}$		12	15	18	ns
Propagation delay INPUT - TTL OUT	$t_{PD\_TTL}$		16	19	22	ns
Delay programmable range	$t_{RANGE}$	Equivalent to $t_{DELAY}$ (max)	45	50	55	ns
Delay programmable range Temperature variation	$\Delta t_{RANGE}(T)$			75		ps/ $^{\circ}$ C
Random timing jitter (RMS)	$Rt_{jitter}$	$t_{DELAY} = 0$ ns		2	5	ps
		$t_{DELAY} = t_{range}$		5	12	ps
Delay step	$\Delta t_{DELAY}$			10		ps
Delay integral non linearity	INL	Full scale range	-100		50	ps
Input frequency divider factor			1		999	
OUTPUT pulse duration	$t_{OUTPUT}$		1		250	ns
OUTPUT pulse step	$\Delta t_{OUT}$	Pulse width incremental step	3	3.3	3.5	ns
OUTPUT off time	$t_{NIM\_OFF}, t_{TTL\_OFF}$	$t_{NIM\_OFF}$ and $t_{TTL\_OFF}$ are not guaranteed to be the equal.	1	3		ns
OUTPUT pulse width jitter	$t_{OUT\_jitter}$	% of pulse duration			1	%
OUTPUT pulse width INL	$t_{OUT\_INL}$		max ( $\pm 5\%$ , 1 ns)			
Programming time	$t_{PROG}$				1	ms
12V Power Supply (INPUT)	VCC12V	12 V board's power supply	11	12	13	V
3.3V Power Supply (OUTPUT)	VCC3V3CMOS	3.3V internal logic power supply	3.2	3.3	3.4	V
12V Power supply -current- SINK	VCC12V	Maximum DC current absorbed by the 12V power supply			1	A
3.3V Power supply -current- SOURCE	VCC3V3CMOS	Maximum current that can be sourced by the 3.3V power supply			500	mA
GND	GND	Board ground			N/A	
$V_{IL\_I/O}$ (I/O INPUT)	RX1, CPLD_FUT_X PIC_FUT_X_Disable_output		0		0.4	V
$V_{IH\_I/O}$ (I/O INPUT)	RX1, CPLD_FUT_X PIC_FUT_X_Disable_output		2.8		3.3	V
$V_{OL\_I/O}$ (I/O OUTPUT)	TX1, CPLD_FUT_X PIC_FUT_X, CPLD_Fin/2	High Z termination	0		0.4	V
		50 Ohm termination	0		0.2	V
$V_{OH\_I/O}$ (I/O OUTPUT)	TX1, CPLD_FUT_X PIC_FUT_X, CPLD_Fin/2	High Z termination	2.8		3.3	V
		50 Ohm termination	1.6		2.4	V
CPLD_Fin/2 - frequency			100	120		MHz
USB power supply	USB_vbus	Refer to standard USB specifications	4.5		5.5	V
USB data signal plus	USB_d+	Refer to standard USB specifications			N/A	
USB data signal minus	USB_d-	Refer to standard USB specifications			N/A	
USB ground	USB_gnd	Refer to standard USB specifications			N/A	

## System requirements

- USB 1.1 and 2.0 interface
- Picosecond Delayer software
  - Microsoft Windows XP, Vista, 7, 8, 32 or 64 bit versions
- Virtual COM
  - Microsoft Windows XP, Vista, 7, 8, 32 or 64 bit versions
  - Linux Ubuntu 12.04 LTS, Fedora Core 15 or compatible distributions, 32 or 64 bit versions.
  - Mac OS X 10.7.5 and above

## Mechanical drawings

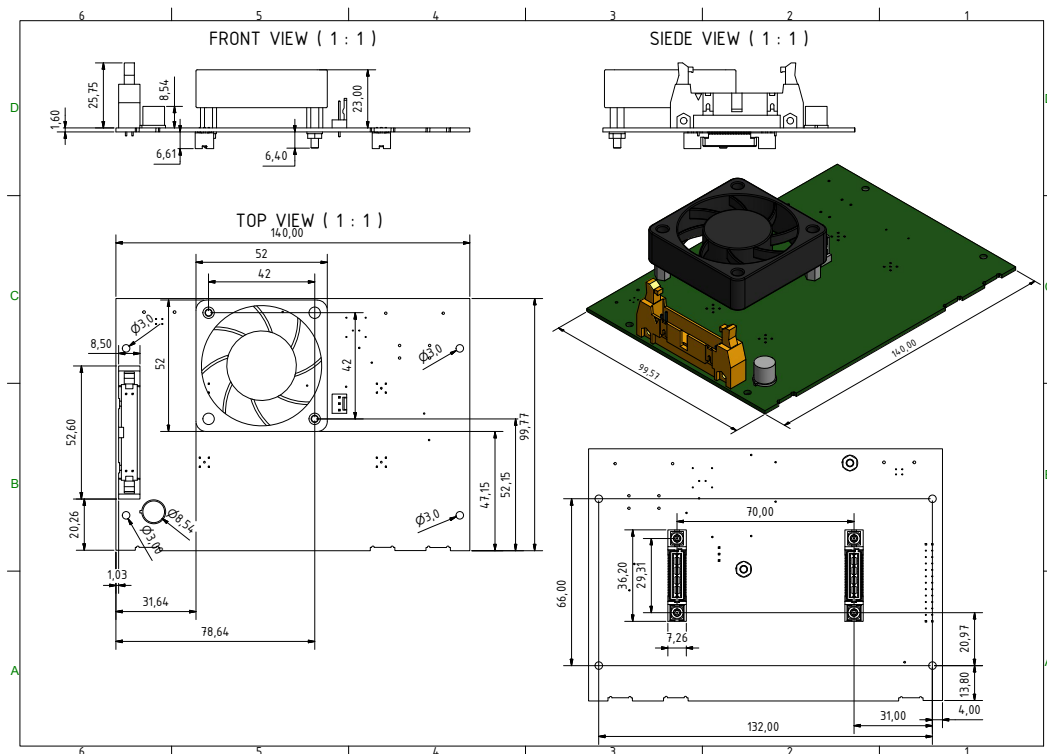

## Ordering Information

The Picosecond Delayer can be ordered directly from Micro Photon Devices or its representatives. For a complete list of representatives, visit our website at [www.micro-photon-devices.com](http://www.micro-photon-devices.com). The ordering code is the following:

***\$PSD - 065 - A - OEM***

## Warranty

A standard legal warranty according to local legislation applies following shipment. Any warranty is null and void if the module case has been opened or if the absolute maximum ratings are exceeded. Specifications are subject to change without any notice. Document version 2.2 – October 2014.

## Contacts

Micro Photon Devices S.r.l, Via Stradivari 4, I-39100 Bolzano, Italy  
 T: +39 0471 051212 F: +39 0471 501524  
[www.micro-photon-devices.com](http://www.micro-photon-devices.com)