

BIOSHAPE LASER

Fully optically integrated laser Top Hat illumination system for life sciences, environmental and scientific applications.

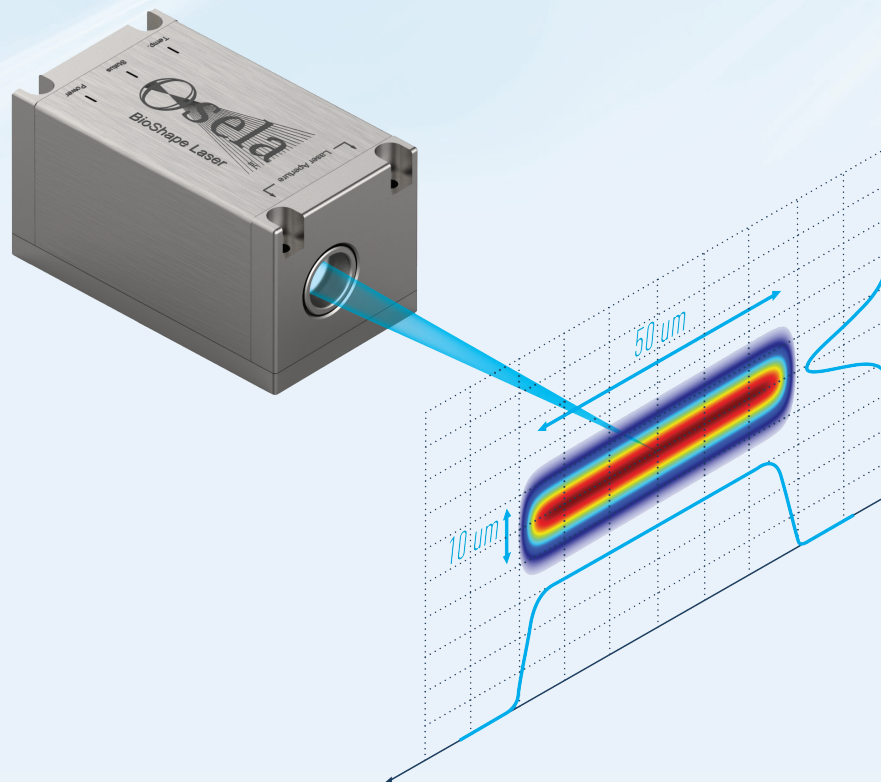

FEATURES

- Compact, standardized dimensions
- Easy to integrate into existing analytical instruments
- Temperature stabilized optical train
- Low noise electronics (<0.2%)
- Integrated communication
- Fast analog and digital modulation

APPLICATIONS

- DNA sequencing
- Flow cytometry
- Environmental monitoring
- Medical instrumentation
- Microscopy
- Laser induced fluorescence and scatter

BEAM SHAPING TO USER'S APPLICATION

Osela's BioShape laser is an OEM ready laser source that allows for easy system integration and is optically beam shaped specifically to user's application. Our flexible optical platform efficiently creates a Top Hat beam profile with high uniformity and no high frequency noise as required in many analytical instruments. The Top Hat beam can be created directly at customer's target plane (**ITH option**) or at the focal plane of an existing optical system (**DTH option**).

KEY FEATURES OF OSELA'S TOP HAT BEAM SHAPING TECHNOLOGY

- Highly uniform profiles (CV down to 1%)
- All glass freeform optics providing high transmission efficiency
- Smooth slow variations with no high frequency noise
- High edge steepness with maximized contained power
- Flexible aspect ratio profiles can be compensated for image plane uniformity.

TOP HAT AXIS PROFILE

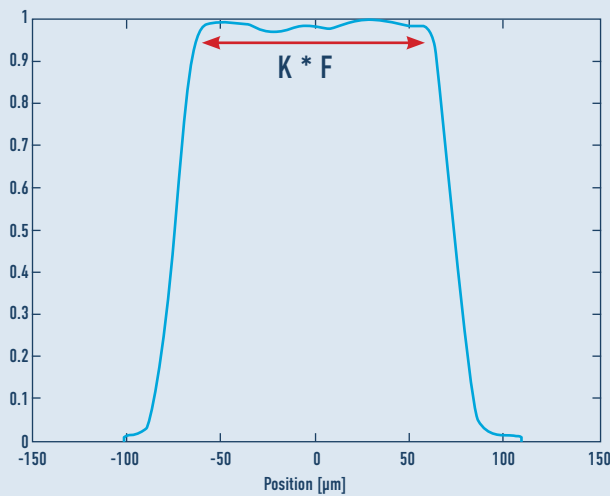

GAUSSIAN AXIS PROFILE

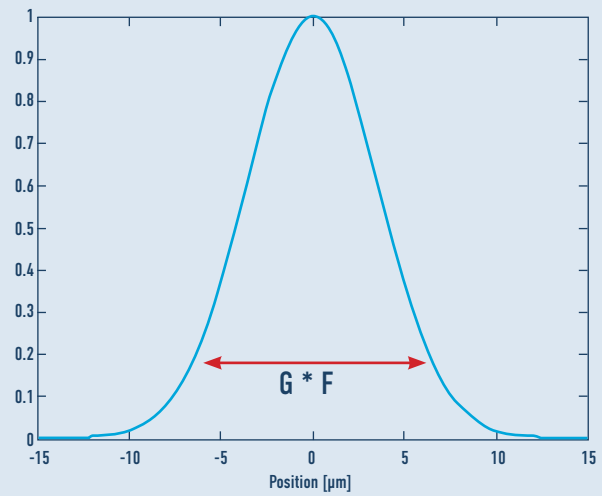

The Top Hat dimension is a function of the Top Hat constant (K) and is directly proportional to the focal/image plane of an optical system (F). Osela offers a wide variety of Top Hat constants and imaging lenses (F) to choose from, providing all the flexibility required for the most demanding Bioinstrumentation applications.

For the opposite Gaussian axis there are many options to choose from, providing great flexibility to the end user. The Gaussian axis is dependent on the focal length of the imaging lens system (F) and the G constant which is itself dependant on the model of the laser.

SPECIFICATIONS

TOP HAT DIMENSION/ROI (μm)	$K * F$ (mm)
TOP HAT CONSTANT (K)	1, 1.5, 2, 2.5, 3, 3.5, 5, 6, 8, 10, 15, 20, 30, 4, 50, 70, 90
TOP HAT UNIFORMITY OVER ROI (Cv)	down to 1%
TOP HAT CONTAINED ENERGY OVER ROI	> 80% (typical)
GAUSSIAN AXIS DIMENSION (μm @1/e ²)	$G * F$ (mm) dependent on Model
GAUSSIAN AXIS CONSTANT (G)	See Model table
IMAGING LENS (F) ITH OPTION ONLY	15, 20, 25, 30, 40, 50, 75, 100 mm

OPTIONS

ITH OPTION

FULLY INTEGRATED BIOSHAPE LASER

Osela's ITH option is a fully integrated, OEM ready laser that creates a Top Hat profile of desired dimension at the focal plane of its integrated imaging lens system. The Top Hat dimension is directly proportional to the focal length of the imaging lens (F) and the Top Hat constant (K), with no additional optical system required.

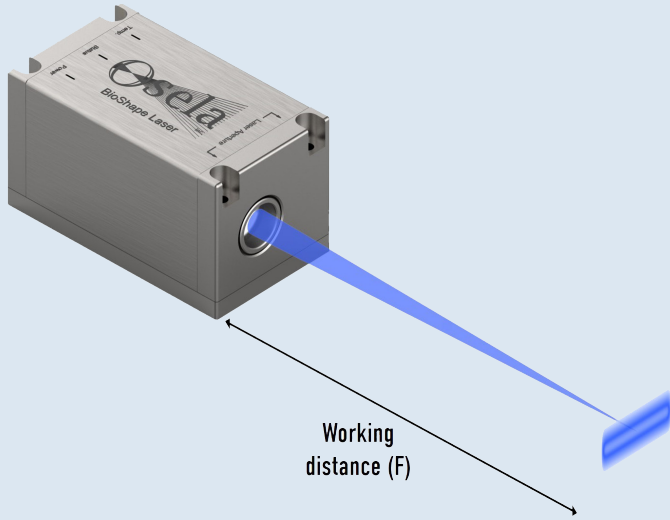

DTH OPTION

FLEXIBLE BIOSHAPE LASER

Osela's DTH option is designed to create a Top Hat profile at the focal plane of a customer's existing optical system. The Top Hat dimension and Gaussian axis are flexible and scale with the effective focal length of the system. This option has the advantage of being independent of distance between the laser and the imaging system.

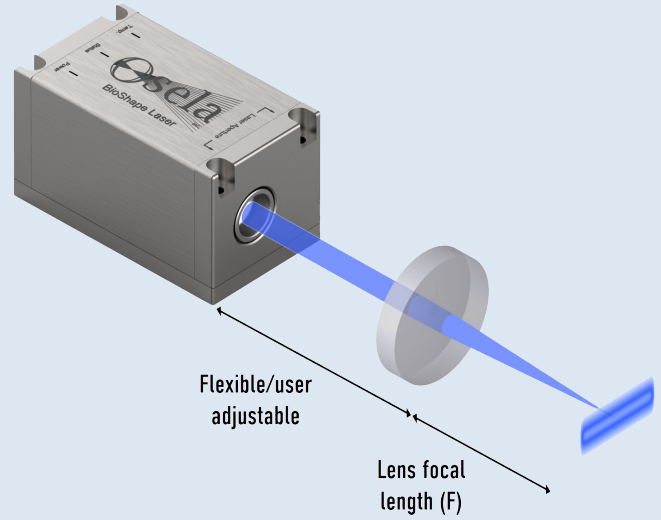

AVAILABLE MODELS

MODEL ¹	375	395	405	420	445	450	455	460	473	488	505	515	520	633	640	660	685	785	830
Wavelength (nm)	375	395	405	422	445	450	455	460	473	488	505	515	521	633	640	660	685	785	827
Tolerance (nm)	±5	±5	±5	±3	±5	±10	±5	±5	±5	±5	±2	±5	±10	±3	±5	±6	±15	±10	±10
Diode Power (mW)	70	120	120 150 300	120	100	80	100	100	100 300	60 200	80	80 150	50 520	100	150 200	50 100 200	50	50 120	50 100 250
Gaussian Axis Dimension Constant²																			
G (Min)	0.1	0.1	0.15	0.15	0.15	0.15	0.1	0.1	0.1	0.1	0.1	0.1	0.15	0.15	0.2	0.25	0.2	0.2	0.2
G (Max)	0.4	0.55	0.4	0.55	0.45	0.45	0.5	0.5	0.45	0.55	0.5	0.5	0.5	0.85	1	0.9	0.85	0.75	1.3

¹Additional models (wavelengths & optical powers) available upon request

²Typical values are presented as reference only. A +/-10% variation is to be expected. Custom G values available upon request.

Osela's many years of beam shaping expertise and our flexible platforms allows us to readily adapt to customer requirements. Many beam shaping options are not listed, please do not hesitate to call our application engineers with your custom beam shaping requirements. Ask for our TOP HAT FUNDAMENTALS APP NOTE for more detailed information on our technology.

FULLY INTEGRATED, HIGH PERFORMANCE LASER PLATFORM

Laser Specifications	
Power Stability	<2% (drift over 48h at room temperature $\pm 3^{\circ}\text{C}$)
RMS Noise	<0.2% (20 Hz - 20 MHz)
Pointing Stability	< 5 $\mu\text{rad} / \text{C}$
M ²	< 1.2
Analog Modulation	500 KHz max., <0.7 us Rise/Fall time (10 % - 90 %),
Digital Modulation	5V TTL or LVDS signal levels, < 5 ns (10 % - 90 %) Rise/Fall time, 70 MHz
Communication	RS232, RS485, USB, no external device required.
DC input	12 V DC, 2A
Power consumption	< 25W
Heat dissipation	< 12 W (baseplate @ 50 °C)
Warm-up time	< 5 min
Temperature	15°C - 40°C (operation), -10°C - 60 °C (storage)
Relative humidity	< 90 % (non-condensing)

MECHANICAL SPECIFICATIONS

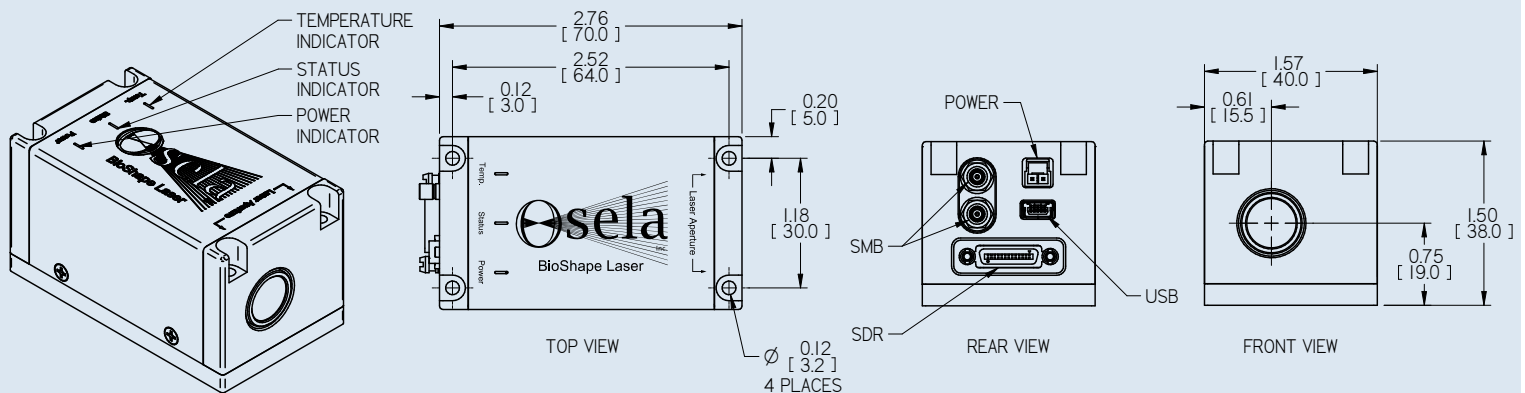

ORDERING CODE

BSL	-	WAVELENGTH	-	POWER	-	Option	-	TOP HAT CONSTANT (K)	-	IMAGING LENS (F)	-	GAUSSIAN AXIS (G)
		See Models Table				ITH DTH		See Specifications Table		See Specifications Table Customer's focal length		See Table

Example 1: ITH option (fully integrated Bioshape laser) at 60mm working distance

EX: BSL-405-100-ITH-1.5-60-0.17

Osele's Bioshape laser, imaged Top Hat option 405nm wavelength, 100mW diode power, 90 μm Top Hat by 10 μm Gaussian axis

Example 2: DTH option (Flexible BioShape Laser) at focal of external 100mm Imaging lens

EX: BSL-488-60-DTH-20-100-0.5

External Imaging lens option, 488nm wavelength, 60mW diode power, 2000 μm Top Hat by 50um Gaussian axis