



The optical retardation can be given without the wavelength dependence for all visible ranges. It can be used in optical systems that change the polarization direction of the white-light source or spectroscopic measurement using polarization.

- There are two types of Fresnel rhomb waveplate, a half waveplate can rotate the polarization orientation and a quarter waveplate can convert linear polarization into circular polarization.
- As the entrance, exit and reflecting surfaces are processed to provide high parallelism and to minimize beam deflection.
- When the linear polarization orientation of incident light is 45 degrees against the sides of square faces, the specified optical retardation will be obtained. The light will exit as linear polarization with -45 degrees orientation for the half waveplate, and as circular polarization for the quarter waveplate.



Schematic

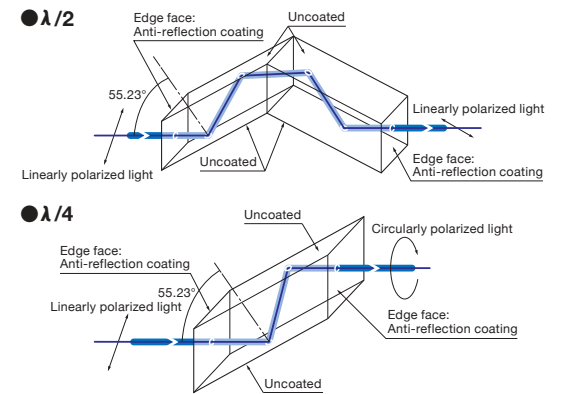

Outline Drawing (in mm)

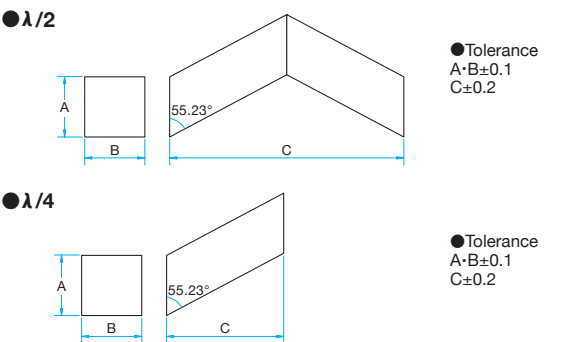

Specifications

Material	BK7
Surface flatness of substrate	$\lambda/10$
Coating	Edge faces: Anti-reflection coating Side surfaces: Uncoated
Design wavelength	587.6nm
Incident angle	0°
Surface Quality (Scratch-Dig)	40-20

Guide

- ▶ Fresnel rhomb waveplates made of synthetic fused silica are also available.
- ▶ For Fresnel rhomb waveplates with different size, wavelength range, or retardation, please contact our Sales Division with your requests.

Attention

- ▶ The quarter waveplate has optical axis shift (refer to the optical axis shift listed in the table below). Use the Fresnel rhomb waveplate by mounting it horizontally or vertically and rotating the polarization orientation of the incidence beam.
- ▶ If finger prints or grease stain the polished surfaces of the Fresnel rhomb waveplate, the specified optical retardation will not be obtained. Use it carefully to prevent the side surfaces from contacting anything. (An FRH mounted in a holder is also available).
- ▶ If the incidence angle varies, the specified optical retardation performance will not be obtained.
- ▶ The Fresnel rhomb waveplate is less dependant to the wavelength, and it can be used in extended range outside the visible range. However the effectiveness of the anti-reflection coating drops outside the visible range and the transmittance decreases.
- ▶ When the linear polarization orientation of incident light is aligned at 0 degrees or 90 degrees against the side of square face, the polarization orientation will not change output. (this is same for half waveplate and quarter waveplate)

$\lambda/2$		
Part Number	A×B×C [mm]	optical axis shift [mm]
FRB-1010-2	10×10×40.0	<0.5
FRB-1515-2	15×15×58.6	<0.5

$\lambda/4$		
Part Number	A×B×C [mm]	optical axis shift [mm]
FRB-1010-4	10×10×20.0	13.5
FRB-1515-4	15×15×29.3	20.2

Fresnel Rhomb Waveplate Holders

We offer holder specifically designed for mounting our fresnel rhomb waveplates. For a $\lambda/2$ plate (FRH-**2), the optical axis of waveplate and rotation axis of holder are aligned.

Outline Drawing (in mm)

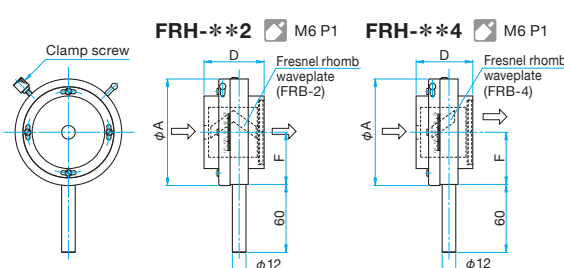

Part Number	Center height F [mm]	Diameter phi A [mm]	Length D [mm]
FRH-102	46	phi94	53
FRH-152	57.5	phi116	74
FRH-104	46	phi94	50
FRH-154	57.5	phi116	46

Specifications

Part Number	Part number of waveplate	Sensitivity [°]	Weight [kg]
FRH-102	FRB-1010-2	1	0.59
FRH-152	FRB-1515-2	1	1.05
FRH-104	FRB-1010-4	1	0.57
FRH-154	FRB-1515-4	1	1.81