

RST Series Datasheet



- Continuous 360° rotation stage
- 50.8 mm (2 inch) aperture with kinematic mounting options for repeatability of assembly
- 50 kg centered load capacity
- Speed up to 24 °/s and torque up to 10 N-m
- Designed for use with an X-MCB1 Series stepper motor controller or any 2-phase stepper motor controller

Overview

Zaber's RST Series products are motorized rotation stages. Rated for a 50 kg centered load capacity and 10 N-m of torque, they are ideal for high load, angular positioning applications. RST stages are designed for plug-and-play use with any of Zaber's controllers.

Drawings

ZABER

RST Motorized Rotary Stage
dimensions in mm

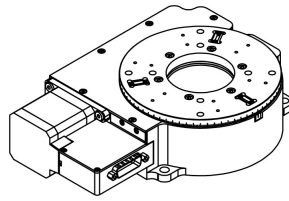

*See product page for complete list of available models at www.zaber.com

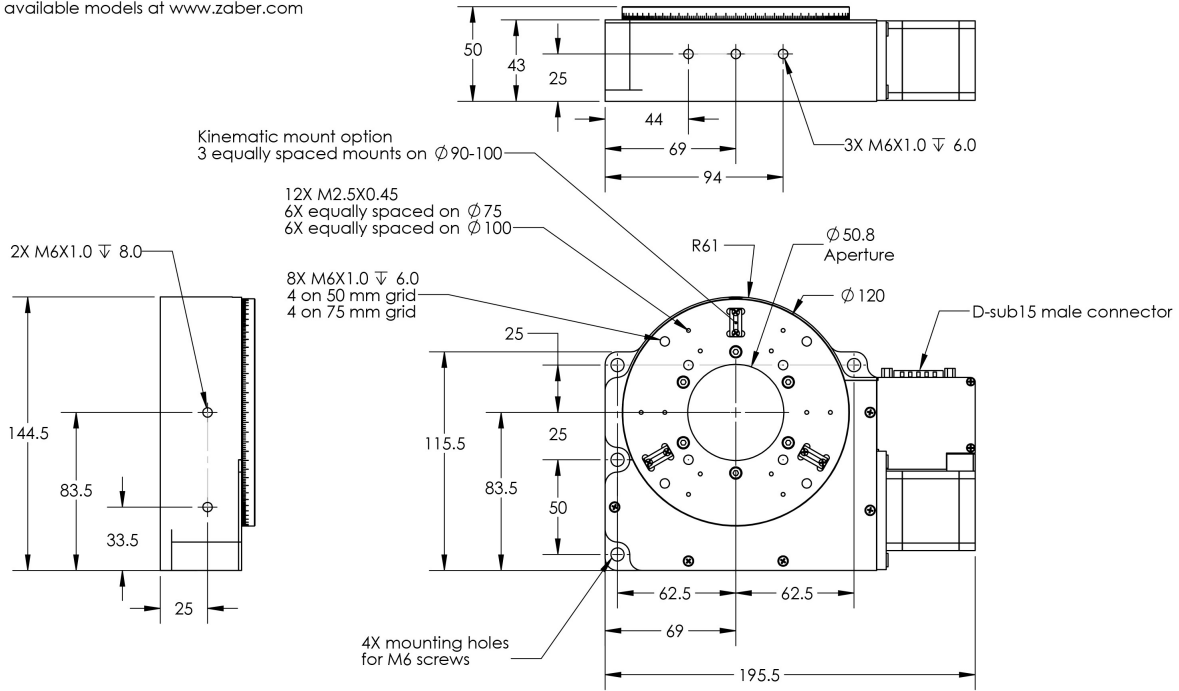

DWG 1183 801

Specifications

Specification	Value	Alternate Unit
Microstep Size (Default Resolution)	0.00015625 °	2.727 μrad
Built-in Controller	No	
Recommended Controller	X-MCB1 (48 V) Recommended	
Range	360 °	
Accuracy (unidirectional)	0.16 °	2.792000 mrad
Repeatability	< 0.005 °	< 0.087 mrad
Backlash	< 0.05 °	< 0.873 mrad
Maximum Speed	24 °/s	4.0 rpm
Minimum Speed	0.000095 °/s	1.658 μrad/s
Encoder Type	None	
Maximum Continuous Torque	1000 N-cm	1416.1 oz-in
Maximum Centered Load	500 N	112.1 lb
Maximum Cantilever Load	2000 N-cm	2832.2 oz-in
Stage Top Dimension	120 mm	4.724 "
Angular Motion Per Motor Rev	2 °	
Motor Steps Per Rev	200	
Motor Type	Stepper (2 phase)	
Motor Rated Current	1500 mA/phase	
Motor Winding Resistance	2.4 ohms/phase	
Inductance	6.6 mH/phase	
Motor Connection	D-sub 15	
Maximum Angular Momentum	0.4 kg-m ² /s	
Mechanical Drive System	Precision Worm Gear	
Limit or Home Sensing	Magnetic home sensor	
Vacuum Compatible	No	
Operating Temperature Range	0-50 °C	
RoHS Compliant	Yes	
CE Compliant	Yes	
Weight	2.40 kg	5.291 lb

Charts

Torque Speed Performance

