

C&L Band ASE Module

Compact ASE OEM Module



Features

- Full C&L Band operation
- 7, 10, 13, 17 & 19 dBm
- Integrated pump laser
- Microprocessor control
- Monitoring electronics
- Customizable

Applications

- Sensing
- Passive components testing
- Bio-medical imaging source

The C&L Band ASE Module is a member of our ASE product family which covers a variety of wavelength ranges, spectral shapes, and output powers. All are available in convenient form factors including: OEM Module and Benchtop.

Mechanical Outline:

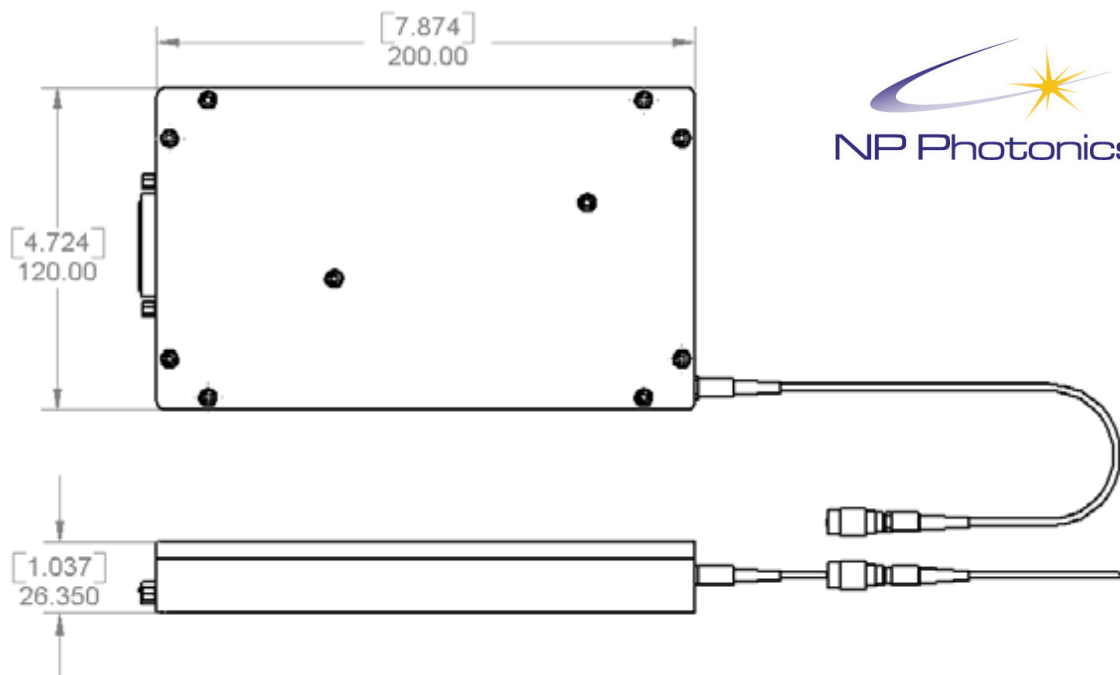

PRODUCT SPECIFICATIONS

Parameter

Wavelength Range	1525 to 1610 nm
Output Power	7, 10, 13, 17 & 19 dBm
Minimum power stability (dB) (1 hr) at fixed °C	± 0.02 dB
Minimum spectral power density (dBm/nm)	-1
Optical Bandwidth @ 10 dB point	> 85 n
Output Polarization (Degree of Polarization)	< 5%
Power Consumption	< 6 W
Package Dimension	200 x 120 x 26.35 mm

Typical Spectra:

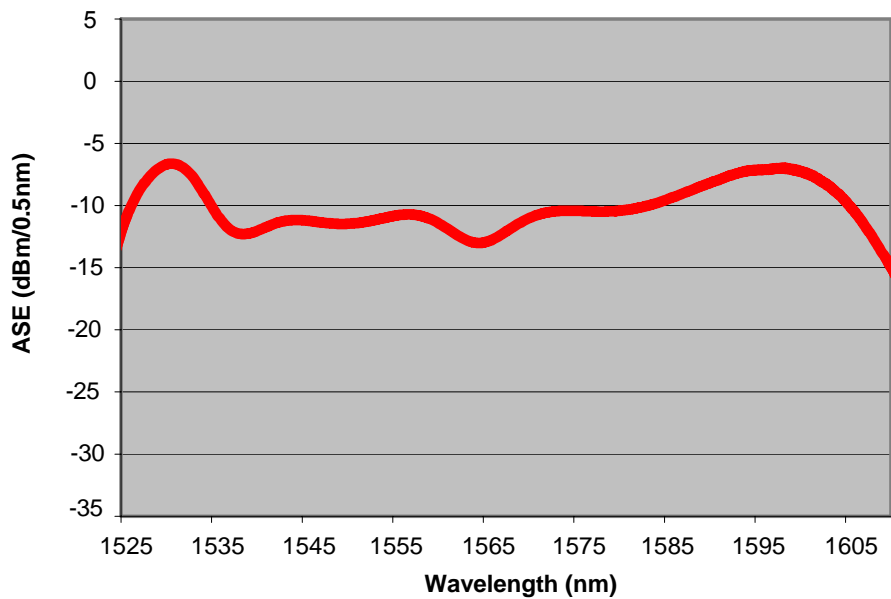

Ordering Example: ASE-CL-M-13-0-U = C&L Band ASE with 13 dBm output power, unflattened, FC/APC connector, Module.

ASE-CL-M

—	—	—																								
<table border="1"> <thead> <tr> <th>Power</th> <th>Code</th> </tr> </thead> <tbody> <tr><td>7 dBm</td><td>7</td></tr> <tr><td>10 dBm</td><td>10</td></tr> <tr><td>13 dBm</td><td>13</td></tr> <tr><td>17 dBm</td><td>17</td></tr> <tr><td>19 dBm</td><td>19</td></tr> </tbody> </table>	Power	Code	7 dBm	7	10 dBm	10	13 dBm	13	17 dBm	17	19 dBm	19	<table border="1"> <thead> <tr> <th>Connector</th> <th>Code</th> </tr> </thead> <tbody> <tr><td>FC/APC</td><td>0</td></tr> <tr><td>Custom</td><td>1</td></tr> </tbody> </table>	Connector	Code	FC/APC	0	Custom	1	<table border="1"> <thead> <tr> <th>Flatness</th> <th>Code</th> </tr> </thead> <tbody> <tr><td>Unflattened</td><td>U</td></tr> <tr><td>Flattened</td><td>F</td></tr> </tbody> </table>	Flatness	Code	Unflattened	U	Flattened	F
Power	Code																									
7 dBm	7																									
10 dBm	10																									
13 dBm	13																									
17 dBm	17																									
19 dBm	19																									
Connector	Code																									
FC/APC	0																									
Custom	1																									
Flatness	Code																									
Unflattened	U																									
Flattened	F																									



NP Photonics C&L Band ASE Modules are protected by a 12-month warranty. All components and assemblies are unconditionally warranted to be free of defects in workmanship and materials for the warranty period, beginning from the date of shipment. This warranty is in lieu of all other warranties, expressed or implied, and does not cover incidental or consequential loss. This warranty does not apply to devices damaged due to operating conditions outside of the specified parameters. Modified warranties for OEM customers are available.